

Large Vehicle Scale RFID

Is it now viable for use?

Antti Permala

Technical Research Centre of Finland (VTT)

12 June 2008



Business from technology

Contents

- Development during last years
- Technology
- Applications
- Cases

Three years after - Development since 2005

- Last Mile solutions - Bestufs 22. April 2005
- MIT developments
- Wal-Mart, Metro – first big cases

Since that

- Standardisation has proceeded → EPC Gen2
- Technology is still developing -> longer read distances, more capacity in chip memory -> more powerful solutions
- How can we benefit?
- When the RFID identification works the next questions deal with ERP integration and visibility along the supply chain
- A lot of closed applications; big roll outs on product, pallet or vehicle level are still in “starting block”

Vision for Transport Telematics Architecture

- **Real-time information about the location, contents and conditions of identified shipments, goods items, parcels and transport vehicles can be collected in a controlled manner.**
- **The collected information can be combined with planning information and refined appropriately to be used during various parts of the process and distributed efficiently and timely to actors.**
- **By collecting, refining and distributing information efficiently organizations can boost their goods transport logistics processes, lower their operational costs and improve their portfolio of logistics services.**

Logistics processes

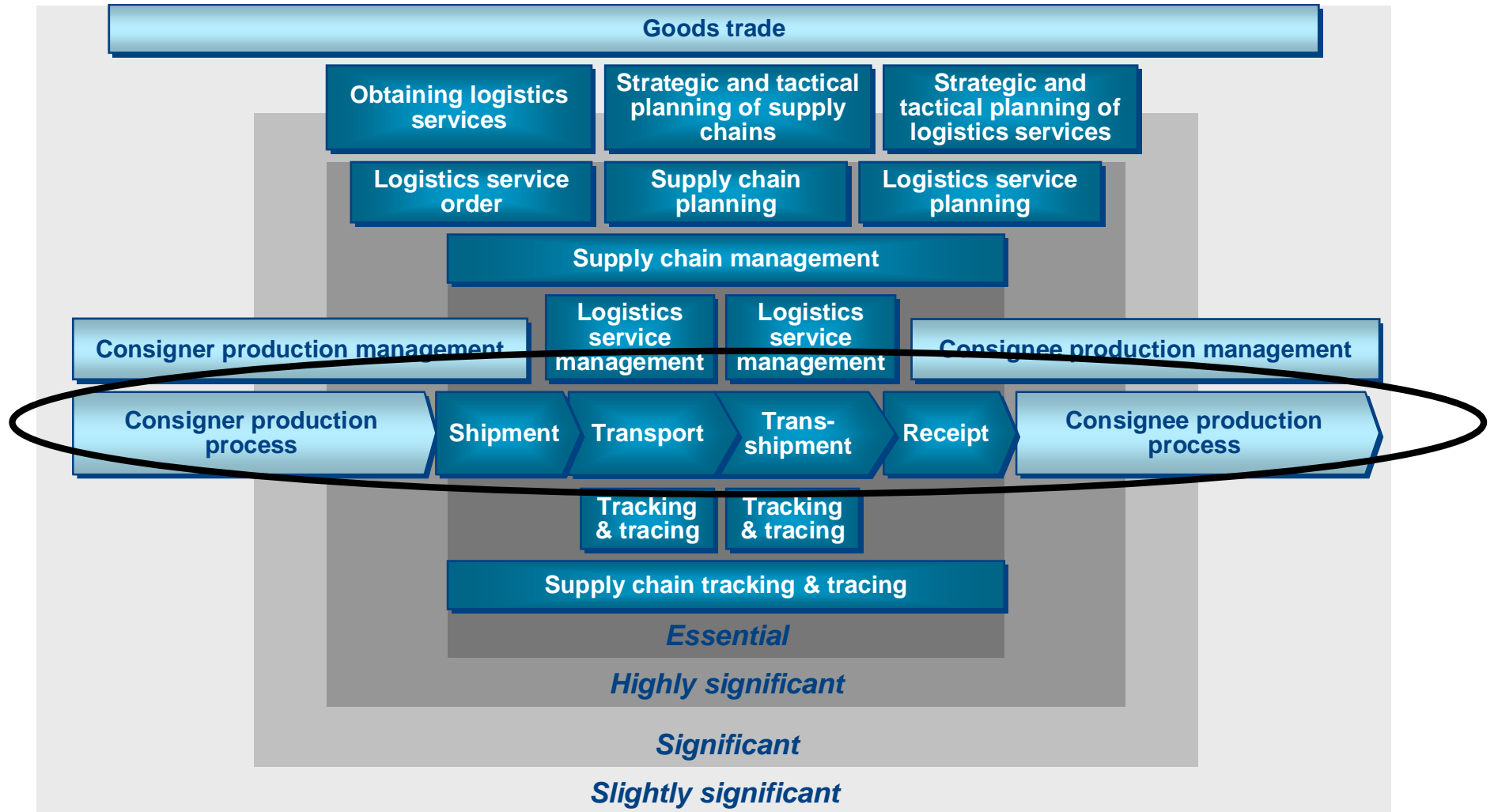

http://www.vtt.fi/rte/projects/fits/julkaisut/hanke1/fits25_2003.pdf

Identification and tracking of goods

- Radio Frequency Identification (RFID) will replace manual identification as well as bar code technology in many applications during the coming years
- Different types of units such as vehicles, containers, roller cages, pallets, plastic boxes and wooden boxes will be equipped with RFID tags
- The tag may contain only ID such as an EAN code or licence plate, the whole transport label or even all transport documents

Radio Frequency Identification (RFID)

- RFID is a wireless identification technology that connects objects to Internet, so they can be tracked, and companies can share data about them.
- Concept: Place a transponder—a microchip with an antenna—on an item and then use a reader—a device with one or more antennas—to read data off of the microchip using radio waves. The reader passes the information to a computer, so that the data can be used to create business value.
- Ultra High Frequency UHF-RFID Standards
 - International Standardisation Organisation ISO-18000-6: UHF (860-960 MHz), ePC (electronic Product Code) - ePCglobal / GS1
- Potential in transport and supply chains e.g. in transport corridor improvements, terminal management and border crossing operations

EPC Memory

- Divided in four parts :
 - Tag-ID
 - Permanent
 - EPC-memory (or UII=Unique Item Identifier) memory
 - 96-bit
 - Can be 495 bit ->
 - Reserved parts:
 - Kill password
 - Access password
 - User Memory

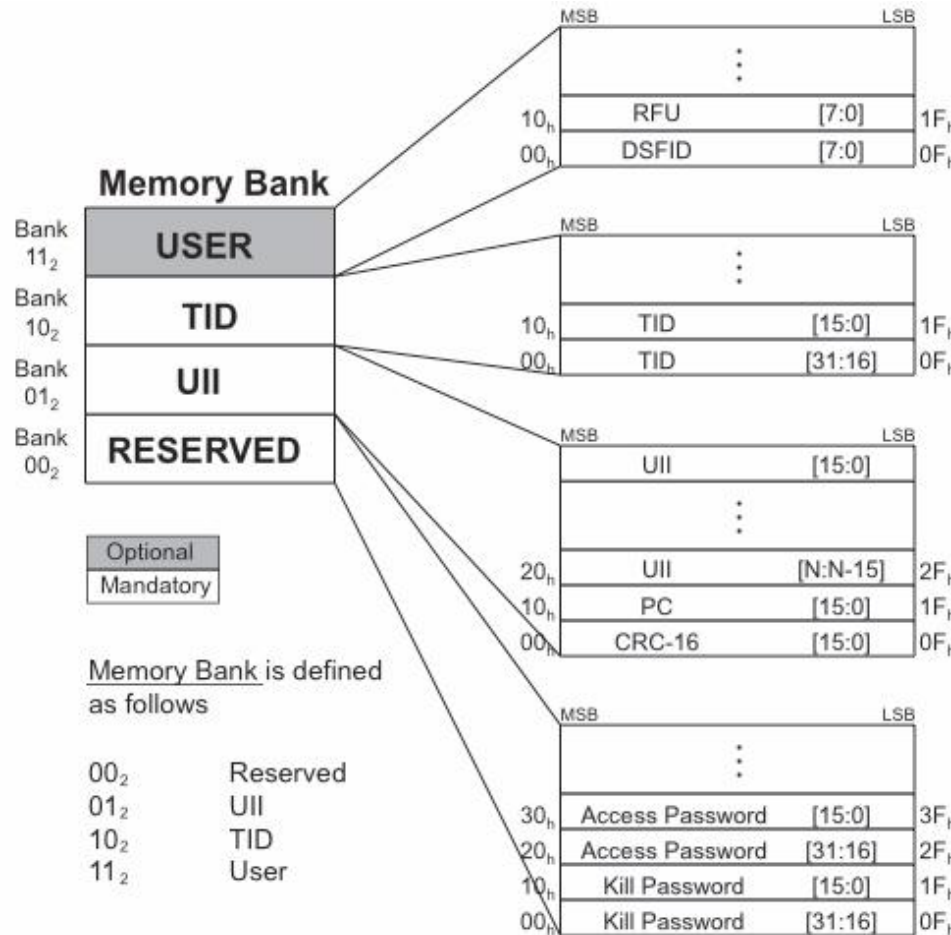

- Data Objects formatted:
 - Precursor, [OID], length, Object
 - Sensors/Battery-assist
 - See ISO/IEC 15961 and ISO/IEC 15962
- MDID
- Part number
- Serial number (optional)
- Burned in or written and permalocked by IC manufacturer
- UII (may be EPC)
- PC (Protocol Control) bits, including UII length indicator
- CRC confirms content of UII memory
- Contains all write lock and kill passwords

ISO vs EPC global

- ISO
 - Unique Item Identifier
 - All information can be in the tag

- EPC/networked
 - Electronic Product Code
 - GS1 (EAN.UCC) number
SSCC, SGTIN
 - All other information in the net
 - Daily consumer goods
 - EPCglobal membership includes fee

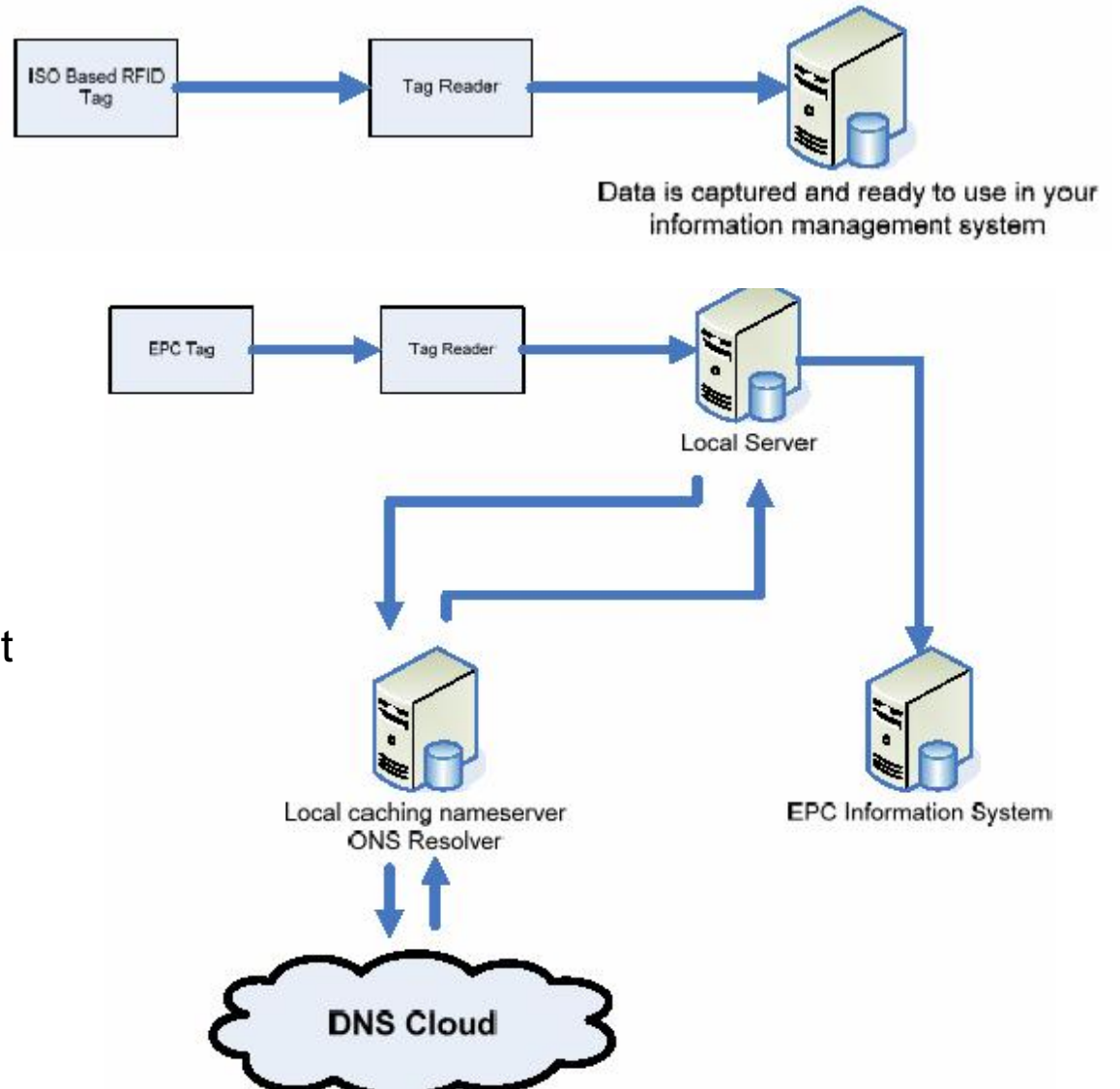

RFID PRODUCT TYPES

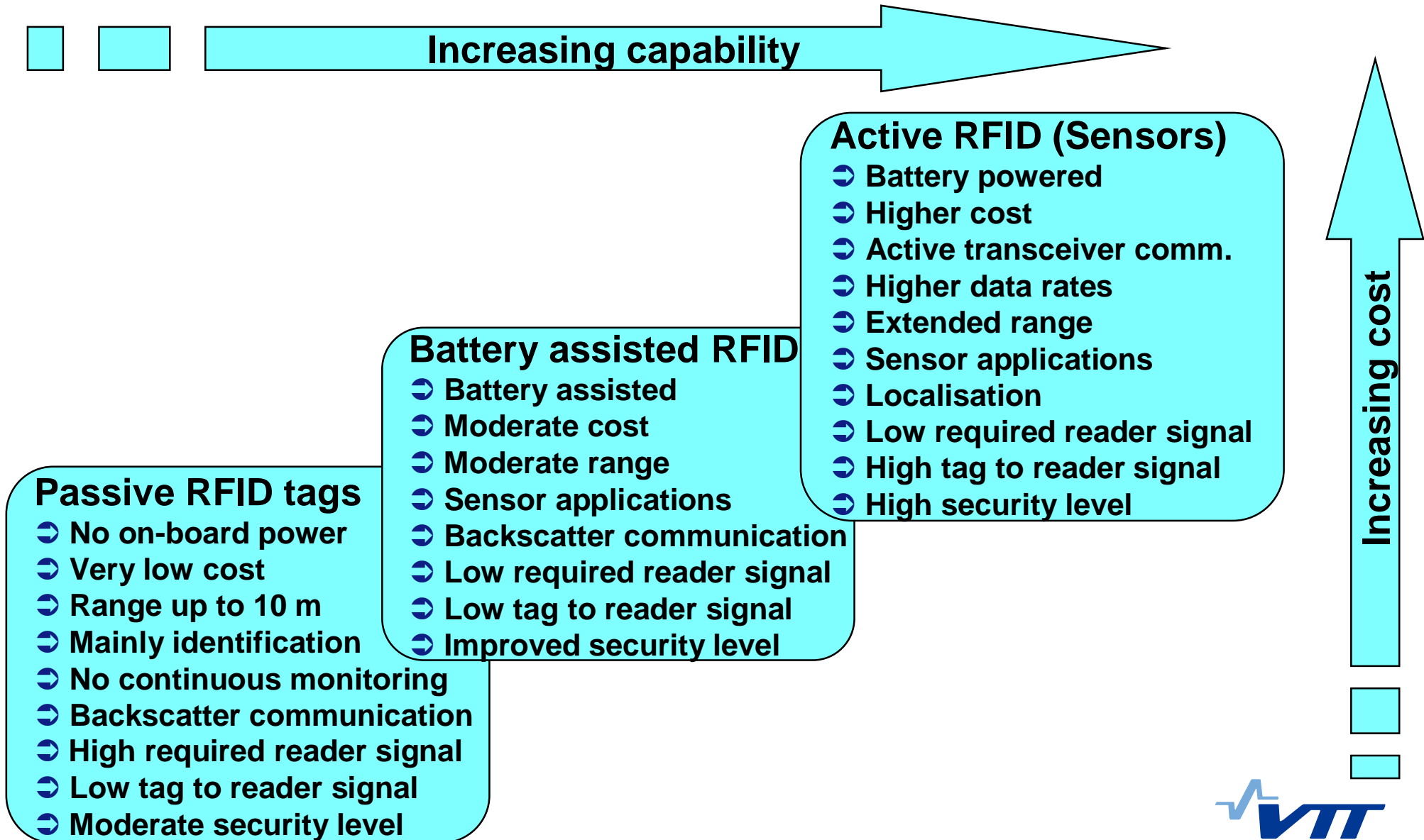

RFID Reference Model

- Logistical Tracking & Tracing
- Production, Monitoring and Maintenance
- Product Safety, Quality and Information
- Access Control and Tracking & Tracing of Individuals
- Loyalty, Membership and Payment
- eHealth Care
- Sport, Leisure and Household
- Public Services

CE RFID: Coordinating European Efforts for promotion the European RFID Value Chain

Identification

- The target for the identification in a supply chain can be the product, transport unit or item, freight container or vehicle.
- Different parties in the supply chain may have very different interests in identification, for example
 - Shipper point of view - the control of the freight,
 - 3PL operator point of view – Managing the sub-contractors
 - Fleet management point of view – optimisation of vehicle fleet
 - Authorities – control of dangerous goods...
- Different tracking levels (vehicle, container, pallet, package) can be linked hierarchically to each other and each party can get the information needed.

DIFFERENT TRACKING LEVELS IN THE SUPPLY CHAIN

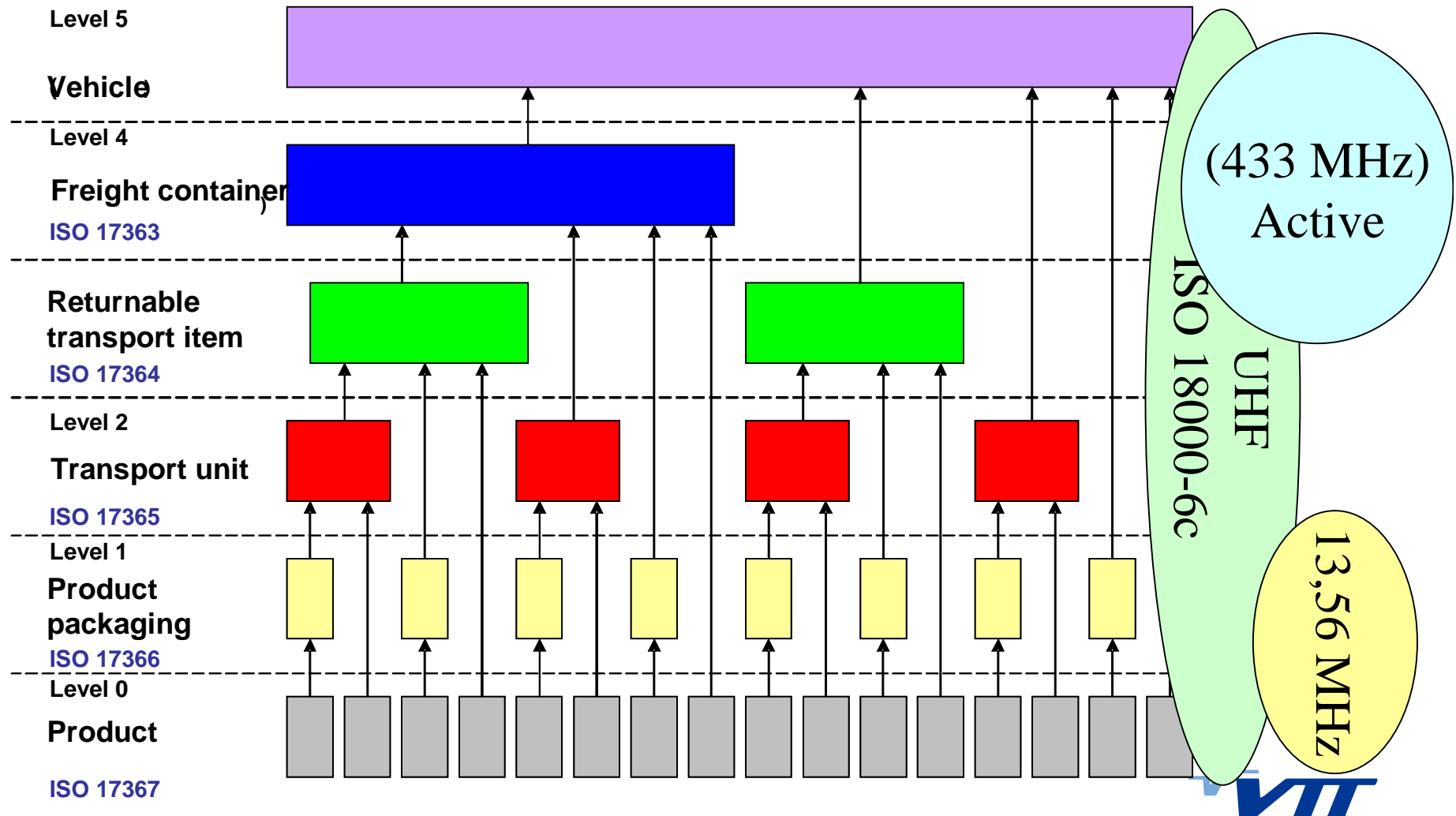

Case plastic box



Identification of pallets with passive RFID

- Case ABB: Tracking of Kanban boxes with suppliers
 - Success story
 - Better visibility, improved operations such as faster order impulses and exception handling, exact statistics about supplies
 - Result - better material control and lower inventories



Loading / Unloading in a Terminal



Your estimate - When RFID systems become common in Finland?

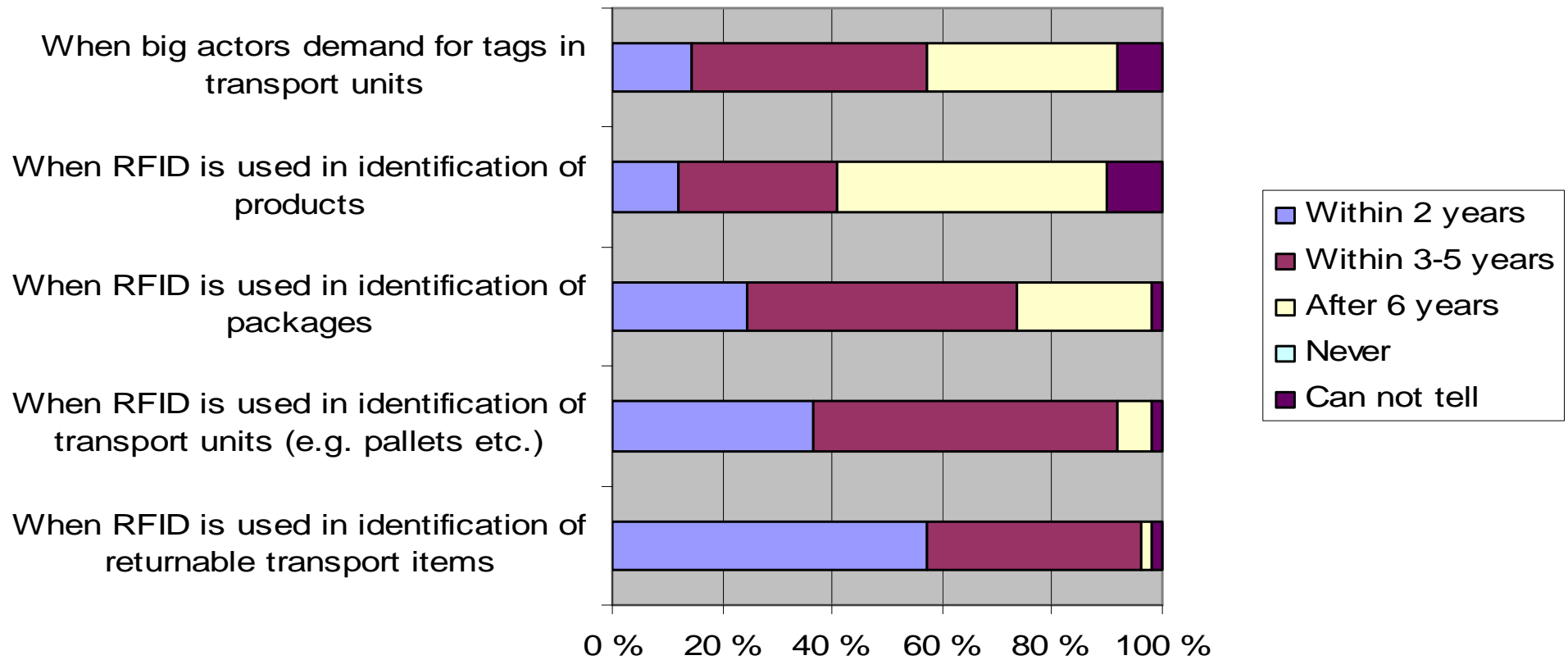

This was done two years ago -> implementation takes time

Results from enquiry with the people who had some experience with the applications

- Doubts about the maturity of technology and standards are the biggest concerns at the moment. Also costs and benefits which can not be verified slow down the implementation in logistics applications.
- The experts have the opposite opinion: according them technology and standards are ready enough for implementations, but this message has not yet been assimilated by possible users.
- The introduction of RFID technology is expected to start from the side of retail. The suppliers start to equip transport items and units with passive UHF tags, mainly according to the mandates from big retail chains such as Wal-Mart, Metro and Tesco.
- When tag prices come down, under 5 c, they can be integrated in consumer packages. Also reader prices will go further down (100 – 200 €).
- No clear view on containers, trucks and trailers

Cases

- Access control – identification of a heavy goods vehicle, identification of a driver, identification of the load
 - Gates, areas, terminals, loading / unloading areas
 - Enables access to unmanned unloading areas
 - Automated reporting
- Automation of terminal operations
 - Vehicle, unit (e.g. pallet), worker identification
 - Loading / unloading
- Traffic monitoring (delivery vans, customer cars, people)
- Toll collection

Cases

Case parking (P-Innovations project)

- Use of passive RFID in car/truck parks. Passive tag is on the wind screen
- Readers in entry and exit



Case Digia: real-time vehicle logistics management

- Temporary identification of vehicles, using passive UHF technology tags which are hanging from rear-view mirror. The system uses mobile hand-held terminals (NordicID)



Case Prosec – Waste management

Case Controlmatic

- Automated sensing, controlling and locating system for fleet operational efficiency
- Fleet operational efficiency ensures overall quality of transportation and transported goods as well as optimising utilisation of transportation assets and security through automated capture and control of sensor data such as position, movement and temperature information.
- System consists of wireless temperature sensors inside containers, units in truck cabins, masters in terminal areas, database and user interfaces.
- Trailer location, continuous temperature measurement, open doors monitoring, position with GPS, and acceleration
- Web based user interface
- Passive and active RFID technology
- Case Suomen Kiitoautot Oy, Wireless sensing and controlling system to 800 trucks, trailers, containers and 10 terminals

COLD STORAGE

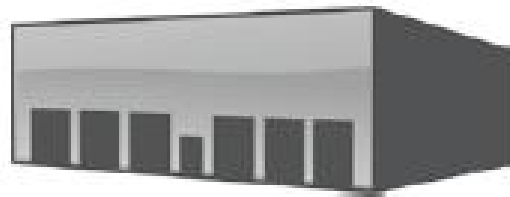

The wireless sensors in the cold store and terminals measure the temperature and send the data to the server for storage.

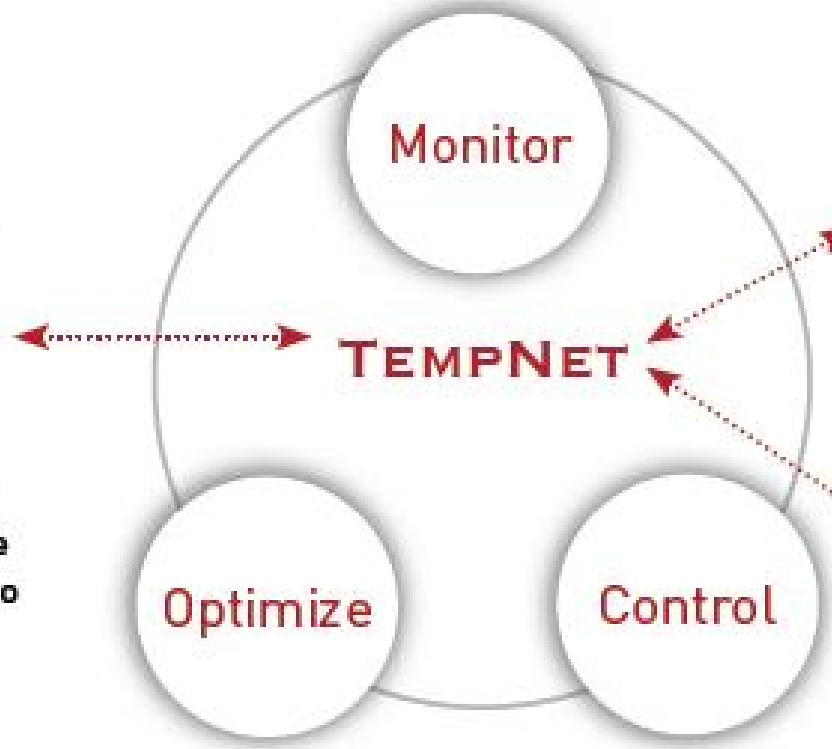

TRUCK



OFFICE





Thank you for your attention

antti.permala@vtt.fi